

Measurement: 2-D and 3-D

Lesson Outline

BIG PICTURE

Students will:

- describe relationships between measured quantities;
- solve problems involving the areas and perimeters of composite 2-D shapes;
- develop volume formulas for pyramids cones and spheres;
- apply knowledge and understanding of 3-D formulas to solve simple problems in context.

Day	Lesson Title	Math Learning Goals	Expectations
1	Fill It Up	<ul style="list-style-type: none"> • Develop through investigation the formulas for volume of a pyramid, and a cone based on the volume of the corresponding prism or cylinder of the same radius and height. 	MG2.04, NA2.01, NA2.03, NA2.04, NA2.08 CGE 5a
2	A Sweet Problem <i>Presentation file:</i> Volume Sphere	<ul style="list-style-type: none"> • Develop through investigation the formula for volume of a sphere based on the volume of a cylinder/cone. • Consolidate volumes of prisms, pyramids, cylinders, cones and spheres. • Solve problems involving combinations of the figures using metric and imperial measure. 	MG2.04, MG2.05, NA2.01, NA2.02, NA2.03, NA2.04, NA2.08 CGE 3c
3	Diagnostic to Activate Prior Knowledge on Composite Figures	<ul style="list-style-type: none"> • Activate students' prior knowledge of terminology related to identifying geometry shapes. • Determine students' readiness to identify geometric figures in composition, and use appropriate calculations for perimeter and area. 	MG2.03 CGE 2c, 5a, 5b
4	Wacky Shapes <i>Presentation file:</i> Composite Figures	<ul style="list-style-type: none"> • Find area and perimeter of composite shapes. • Solve composite area problems, e.g., logos, business signs, irregularly shaped gardens. 	MG2.03, NA2.01, NA2.02, NA2.03, NA2.04 CGE 3c
5	The Rope Stretchers <i>Presentation file:</i> Pythagorean Theorem	<ul style="list-style-type: none"> • Connect the geometric representation of the Pythagorean theorem to the algebraic representation $a^2 + b^2 = c^2$. • Relate their understanding of inverse operations to squares and square roots. 	MG2.01, NA2.02 CGE 5a
6	Using Pythagorean Theorem	<ul style="list-style-type: none"> • Solve 2-D and 3-D problems using the Pythagorean theorem. • Substitute into and evaluate algebraic expressions involving exponents. 	MG2.01, MG2.02, NA2.01, NA2.02, NA2.04, NA2.08 CGE 3c
7		Instructional Jazz	
8		Instructional Jazz	
9	Unit 1 Test	Assessment	



75 min

Math Learning Goals

- Develop through investigation the formulas for the volume of a pyramid and cone, based on the volume of the corresponding prism or cylinder of the same radius and height.

Materials

- 3-D relational solids
- filler beads or sand
- baggies
- paper plates
- BLM 1.1.1, 1.1.2

Assessment Opportunities

Minds On ...

Small Groups → Exploration

Each group works with one set of solids. Orient students to the 3-D relational solids. Allow for exploration time.

Students establish their own criteria and rationale for sorting the various solids into groups.

Whole Class → Sharing

Each group shares its strategy.

Use this opportunity to review the terminology related to the geometric shapes.

If a sufficient number of sets is not available, consider sorting as a whole class and a carousel for Action.

Action!

Small Groups → Investigation

The groups compare the volumes of prisms (cylinder) and pyramids (cone) with congruent bases and equal heights (BLM 1.1.1).

Learning Skills (Teamwork)/Observation/Checklist: Observe how students interact as they investigate in their groups.

Prepare baggies of sand or beads and paper plates in advance of investigation.

Consolidate Debrief

Whole Class → Journal: Representing

Give the class the following journal prompt: Using words, pictures, numbers, and symbols, describe the relationships you discovered today.

Pairs → Pair/Share

Students complete BLM 1.1.2, alternating as indicated between writing and coaching.

Establish the criteria for journal writing and revisit at frequent intervals. Refer to *Think Literacy, Mathematics 7–9, Journal Writing – Developmental Stages*, p. 92.

Differentiated Exploration Reflection

Home Activity or Further Classroom Consolidation

Use the 3-D relational sets and record as many paired relationships as you can. For example, the small, triangular prism is half the volume of the small, square-based prism.

The relationship between the cone and the hemisphere is examined in Day 2.

1.1.1: Investigation – Comparing Volumes

Purpose

Compare volumes of shapes that have the same base and height.

Hypothesis

I think that...

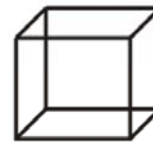
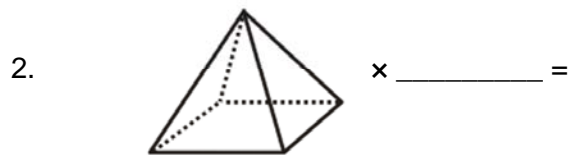

Investigate

How many times will the volume of the shape on the left fill the shape on the right?

1. $V_{\text{cone}} \times \underline{\hspace{1cm}} = V_{\text{cylinder}}$
2. $V_{\text{square pyramid}} \times \underline{\hspace{1cm}} = V_{\text{square prism}}$
3. $V_{\text{triangular pyramid}} \times \underline{\hspace{1cm}} = V_{\text{triangular prism}}$

Conclusion

1.1.2: Pair Share – Volume

Partner A answers question A, partner B coaches.

Partner B answers question B, partner A coaches.

A – Prisms

Circle the shapes that are prisms.

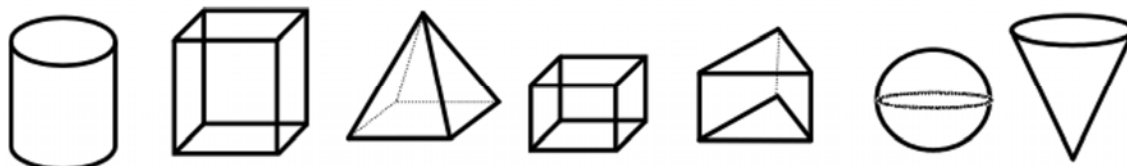

Volume of a prism = area of _____ \times _____.

B – Pyramids

Circle the shapes that are pyramids.

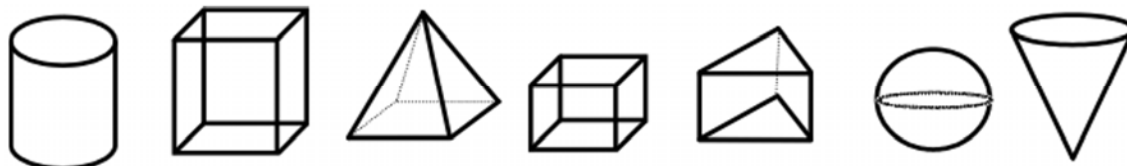

Volume of a pyramid = volume of a prism \div _____.

1.1.2: Pair Share – Volume (continued)

Calculate the volume of the following figures. Show your work.

A

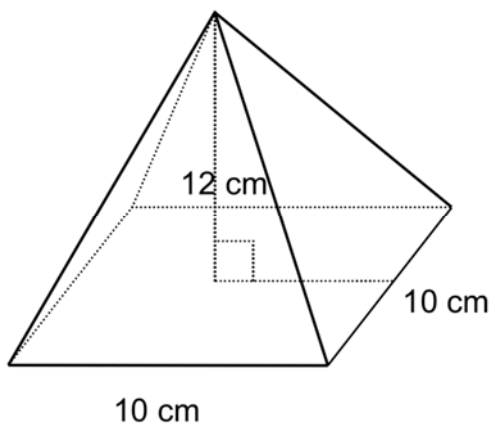

B

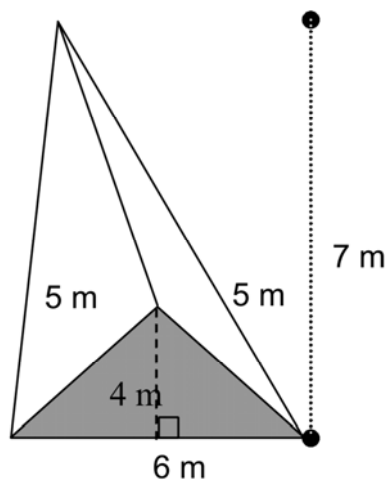

Calculate the volume of the following figures. Show your work.

A

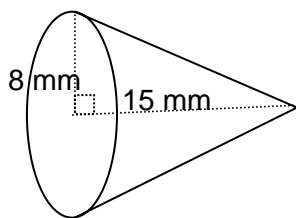

B

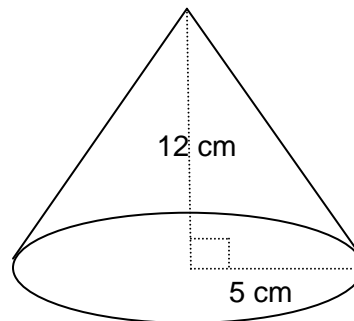

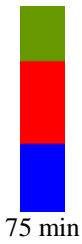

Math Learning Goals

- Develop through investigation the formula for volume of a sphere based on the volume of a cylinder/cone.
- Consolidate volumes of prisms, pyramids, cylinders, cones, and spheres.
- Solve problems involving combinations of the figures using metric and imperial measure.

Materials

- 3-D relational solids
- filler beads
- BLM 1.2.1, 1.2.2
- computer/data projector

Assessment Opportunities

Minds On ...

Pairs → Think/Pair/Share/Discussion

Individually, students make hypotheses about the relative volumes of pairs of 3-D solids. In pairs, they compare and consolidate their lists.

Ask:

- Are there any other pairs where one is 3 times the other? 4 times? 2 times? [hemisphere \times 3 = cylinder; small, triangular-based prisms \times 4 = large, triangular prism; small cylinders \times 2 = large cylinder;]
- Is there a series of shapes which all compare? [square and rectangular-based prisms (all 4 doubling each time)]
- Are there any shapes with equal volume? [hemisphere = cone]

Demonstrate selected examples, emphasizing the connection between the hemisphere and cone.

Action!

Pairs → Investigation

Students complete BLM 1.2.1 using the 3-D relational solids. They read the problem and highlight important information needed to solve the problem.

Reasoning and Proving/Observation/Anecdotal: Listen to pairs discuss to determine their understanding of the relationships being investigated.

Whole Class → Presentation

To develop further understanding of the formula of the volume of a sphere, show the electronic presentation, Developing the Formula for the Volume of a Sphere, which formalizes the relationship between the volume of a sphere and a cone.

Consolidate Debrief

Pairs → Practice

Students solve a variety of problems involving the volume of prisms, pyramids, and spheres (BLM 1.2.2).

Home Activity or Further Classroom Consolidation

Find pictures of buildings/structures in your community that are prisms or pyramids. Choose one of the pictures, estimate the dimensions, and present a complete solution for the volume of the structure.

[VolumeSphere.ppt](#)

Consider using the volume of a sphere as equivalent to two cones until students are ready for the traditional formula.

This could be a pair or small-group activity.

Application Differentiated Exploration

1.2.1: Melting Ice Cream

- Heather purchased an ice cream cone.
- The scoop of ice cream was a sphere.
- The height of the cone equals the diameter of *both* the cone and the sphere.
- If the ice cream melts, how much will overflow the cone?



In Pairs

A. What do we already know?

1.



=

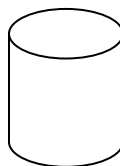

÷ _____

Volume_{cone}

=

Volume _____

÷ _____

2. Volume_{cylinder}

=

(Area of Base) × ()

3. Volume_{cone}

=

(Area of Base) × () ÷ _____

B. Using the two 3-D relational solids of the cone and sphere, compare.

1. Height_{cone} and Height_{sphere}

Comparison:

2. Radius_{cone} and Radius_{sphere}

Comparison:

3. Volume_{cone} and Volume_{sphere}

Comparison:

C. Conclusion

_____ ×



=

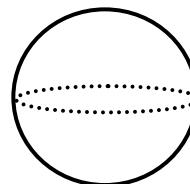

D. How much ice cream will overflow? Write a relationship statement.

1.2.2: Applications of Volume

1. Calculate the volume of the perfume bottle.

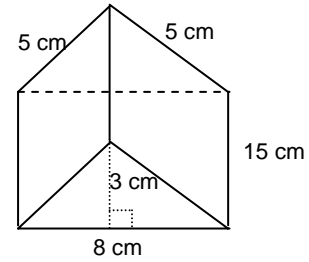

2. How much soup can this container hold?

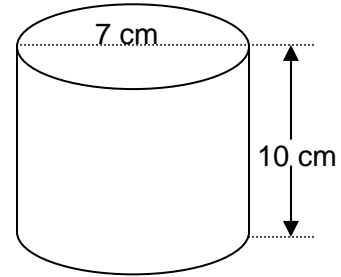

3. Calculate the volume of the rectangular prism.

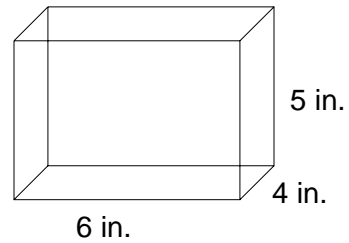

4. Which popcorn container will hold more?

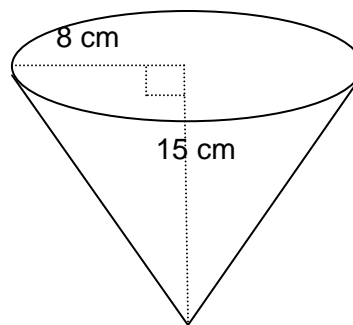
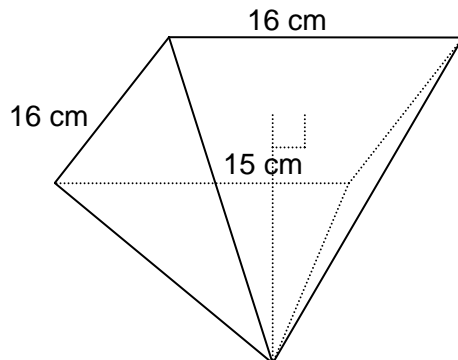

1.2.2: Applications of Volume (continued)

5. How many times bigger is the second sphere?

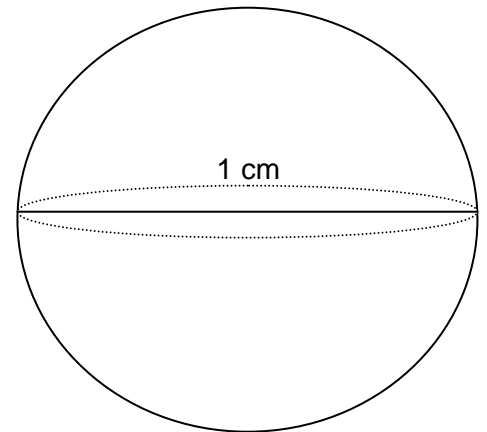
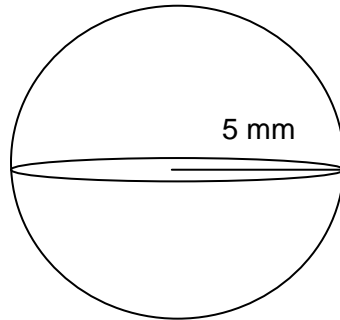

Hint: Change both measurements to the same units!

6. How much more expensive should the large aquarium be than the small aquarium if the cost is based on the volume?

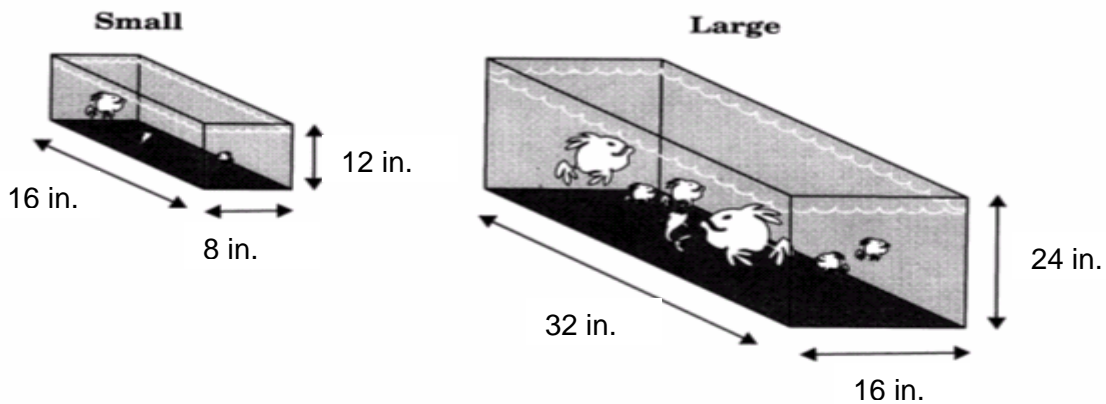

7. Determine the volume of the cabin. Show your work.

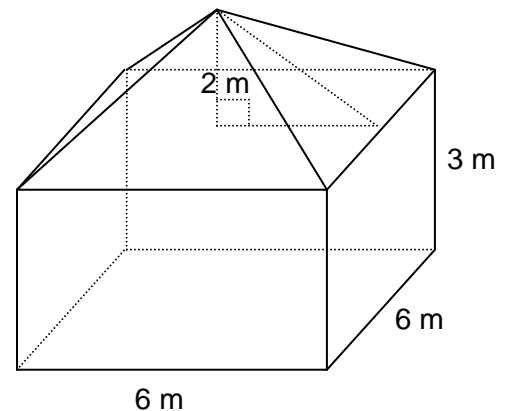

Developing the Formula for the Volume of a Sphere

VolumeSphere.ppt.

(Presentation software file)

1

Developing the Formula for the Volume of a Sphere



2

Volume of a Sphere



Using relational solids and pouring material we noted that the volume of a **cone** is the same as the volume of a **hemisphere** (with corresponding dimensions)

Using "math language" $Volume_{(cone)} = \frac{1}{2} Volume_{(sphere)}$

Therefore $2(Volume_{(cone)}) = Volume_{(sphere)}$

OR 

3

Volume of a Sphere



We already know the formula for the volume of a cone.

$$Volume_{cone} = \frac{Volume_{cylinder}}{3}$$

OR 

4

Volume of a Sphere

AND we know the formula for the **volume** of a cylinder

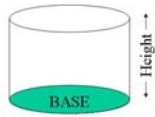
$$Volume_{cylinder} = (Area\ of\ Base) \times (Height)$$

5

Volume of a Sphere



SUMMARIZING:

$Volume_{(cylinder)} = (Area\ Base) (height)$

$Volume_{(cone)} = Volume_{(cylinder)} / 3$



$Volume_{(cone)} = (Area\ Base) (height) / 3$

AND $2(Volume_{(cone)}) = Volume_{(sphere)}$

$2 \times$ 

6

Volume of a Sphere

$2(Volume_{(cone)}) = Volume_{(sphere)}$

$2 \times$ 



$2(Area\ of\ Base) (height) / 3 = Volume_{(sphere)}$

$2(\pi r^2)(h) / 3 = Volume_{(sphere)}$

BUT $h = 2r$



$2(\pi r^2)(2r) / 3 = Volume_{(sphere)}$



$4(\pi r^3) / 3 = Volume_{(sphere)}$

7

Volume of a Sphere

$$Volume_{sphere} = \frac{4 \pi r^3}{3}$$





75 min

Math Learning Goals

- Activate students’ prior knowledge of terminology related to identifying geometry shapes.
- Determine students’ readiness to identify geometric figures in composition, and use appropriate calculations for perimeter and area.

Materials

- BLM 1.3.1, 1.3.2, 1.3.3
- placemat
- overhead projector

Assessment Opportunities

Minds On ...

Whole Class → Orientation

Outline the procedure for the day, including the purposes of each component of the lesson [**Minds On** – activate prior knowledge of shapes, **Action** – review their measurement skills, and **Consolidate** – demonstrate these skills in an activity]. Explain that assessment allows you to plan upcoming lessons according to their current levels of understanding and that the results do not influence their grade in the course.

Small Groups → Pass the Paper

Each group lists the geometric figures in the diagram (BLM 1.3.1). Circulate and provide direction and guidance, as necessary.

Students pass one piece of paper around the group, writing a response each time they receive the paper. Responses should include rectangles, squares, triangles, trapezoids, circles (semi-circles) and may include adjectives, as in ‘equilateral triangle.’

Learning Skill (Teamwork)/Observation/Mental Note: Observe students as they work. Encourage effective communication by referring to groupwork skills.

Pass the Paper is typically a timed activity, usually no more than 2 minutes.

Action!

Pairs → Scale Drawings

Students answer the questions on BLM 1.3.2. Circulate to encourage discussion and to clarify information regarding the diagrams.

Whole Class → Discussion

Using an overhead of BLM 1.3.2, lead a discussion in which students share their answers.

Consolidate Debrief

Individual → Calculate Area

Students draw line segments on the composite figure on BLM 1.3.3. Point out that they must be able to calculate the area of each shape created.

Individual and Groups → Placemat

Describe the procedure for completing a placemat activity. Students individually respond to the question on BLM 1.3.3 for 5 minutes. The members of each group share their procedures, then complete the centre portion of the placemat, providing a model solution to the question. Designate a scribe for each group. Collect the placemats for assessment.

Curriculum Expectation/Placemat/Checkbric: Circulate and observe students as they complete a solution, recording individual strengths and needs.

Whole Class → Discussion

Facilitate group sharing.

Ask students to label their “place” on the placemat for reference.

The results of individual work allows you to differentiate appropriately for further instruction.

Application Differentiated

Home Activity or Further Classroom Consolidation

Choose another example from daily life of a figure that is represented by more than one geometric shape. Include a sketch and estimate the dimensions for the figure used.

1.3.1: Design Details

Name the geometric shapes, using arrows to connect names of shapes to the diagram.

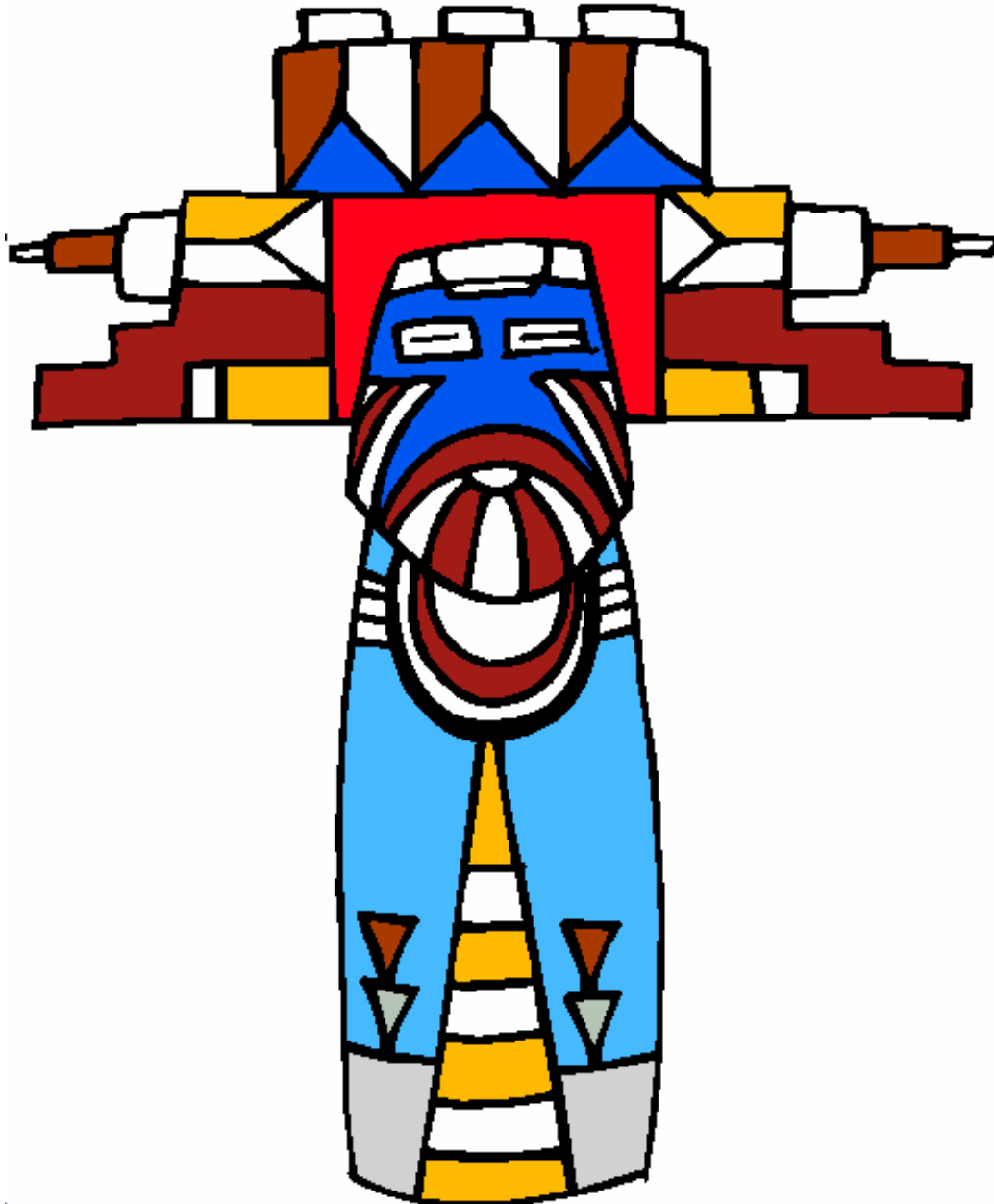

1.3.2: Scale Drawing Details

1. Consider the two composite figures.

(a) Identify the geometric shapes in each. Write the names on the diagrams.

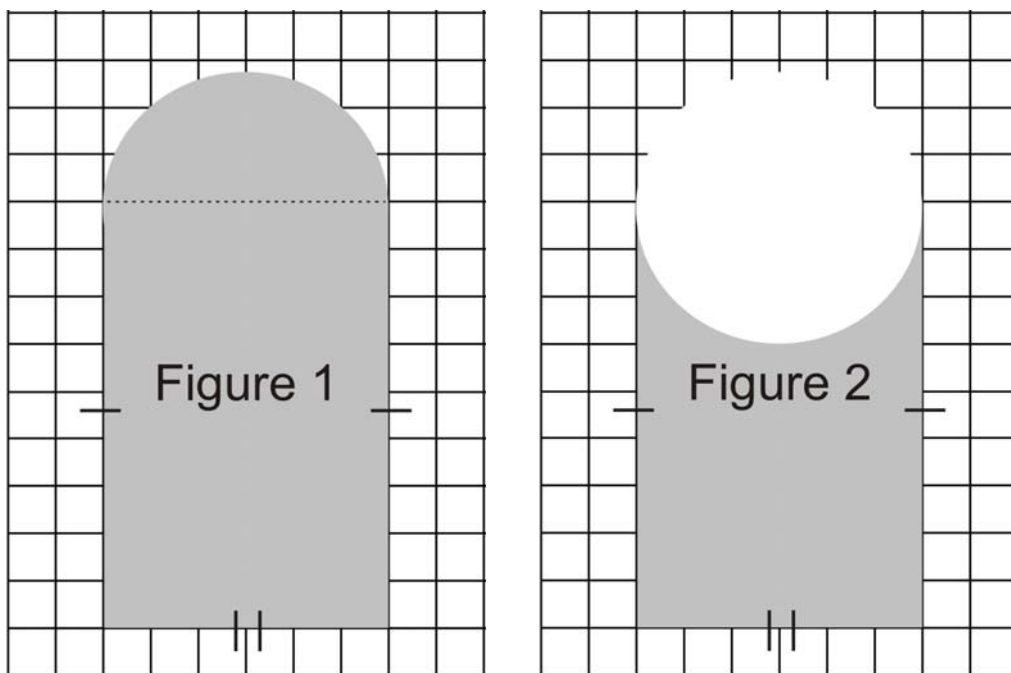

(b) Area

For determining the area of the shaded regions, describe the features and calculations that are:

i) the same

ii) different

(c) Which of the two figures is larger?

By how much?

Justify your answer using pictures, symbols, and words.

(d) Perimeter

Use a coloured pencil to outline the perimeters of the two figures. How do these two perimeters compare?

1.3.2: Scale Drawing Details (continued)

2. Use the diagram below to calculate the area and perimeter of the triangle.

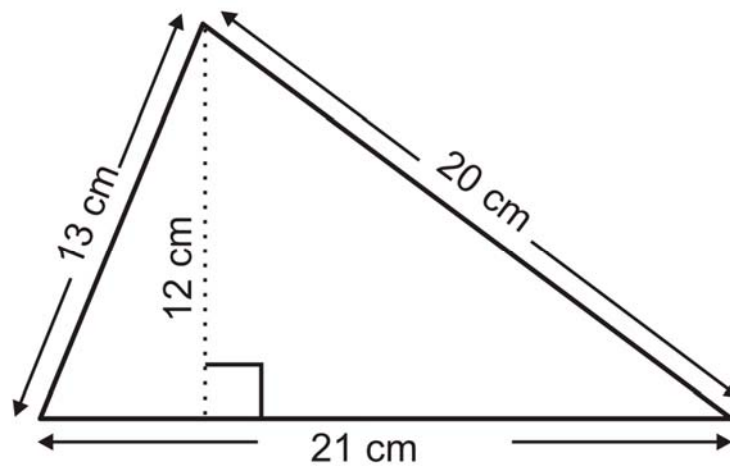

a) What dimensions are needed to determine the perimeter?

b) What dimensions are needed to determine the area?

c) Calculate:

Area

Perimeter

3. Provide an example in daily life of a figure that involves more than one geometric shape.

1.3.3: Area Challenge

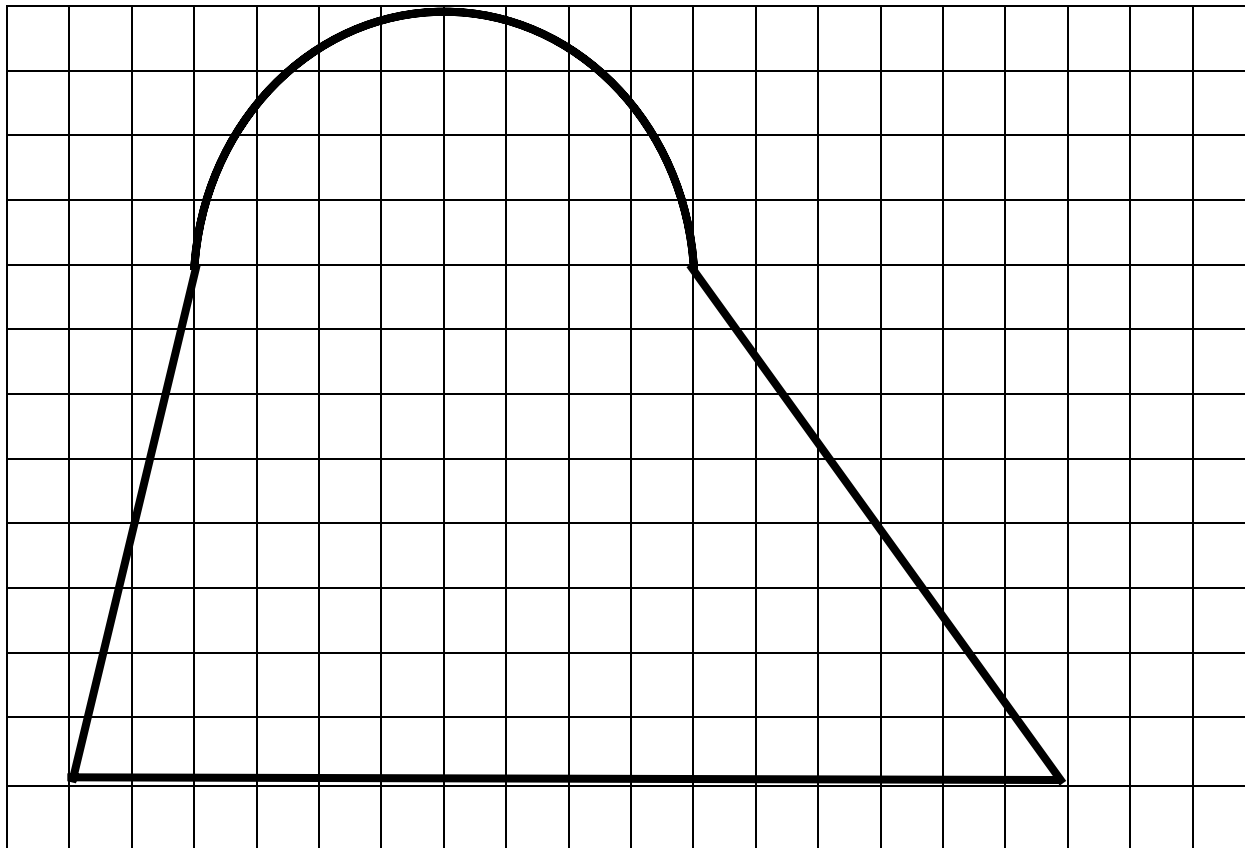

On the diagram, draw line segments to subdivide the shape into simple shapes, and calculate the area.

On the placemat:

In your space, **list** the steps required to determine the area of the figure.

As a group, discuss the steps, then provide one complete **solution** to the problem in the centre of the placemat.



75 min

Math Learning Goals

- Find area and perimeter of composite shapes.
- Solve composite area problems, e.g., logos, business signs, irregularly shaped gardens.

Materials

- overhead projector
- BLM 1.4.1, 1.4.2, 1.4.3, 1.4.4, 1.4.5
- computer/data projector

Assessment Opportunities

Minds On ...

Small Groups → Investigation

Show an overhead of the composite figure on BLM 1.4.1.

In small groups, students subdivide the figure into standard shapes (circles, triangles, rectangles, etc.). Using a blank overhead transparency on top of a copy of BLM 1.4.1, groups subdivide the figures, then present their work to the class.

Whole Class → Presentation

Show electronic presentation, Composite Figures. Students record their answers on BLM 1.4.2.

[CompositeFigures.ppt](#)

Action!

Individual → Exploration

Students explore area of multiple subdivisions as they work through BLM 1.4.3. On the back of the worksheet, students calculate the perimeter of the original shape.

As a class, use individual responses to identify multiple ways of solving the problem.

Pairs → Mathematical Processes

In pairs, students work through BLM 1.4.4.

Mathematical Process/Observation/Anecdotal: Collect work and use for providing anecdotal feedback and for planning further instruction.



Consolidate Debrief

Whole Class → Brainstorm

Brainstorm situations/careers that involve composite figures, e.g., construction, decorating, tile laying, seamstress. Record these on a master list or web.

Complete the Frayer Model for Composite Figures to reinforce characteristics (BLM 1.4.5).

[Word Wall composite figures](#)

Application

Home Activity or Further Classroom Consolidation

Design your dream bedroom! Draw a floor plan and calculate the area and perimeter of your room. It must be a composite figure of at least three shapes.

1.4.1: What Is This?

What shapes are hiding in the drawing below?

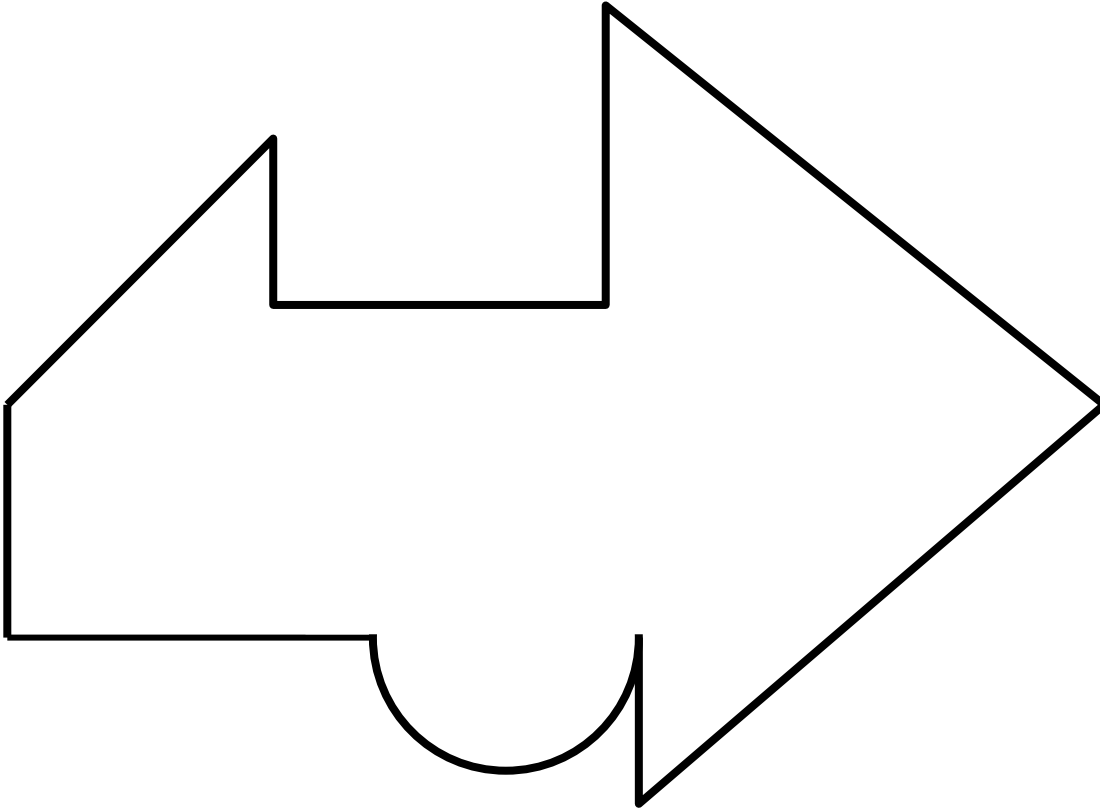

1.4.2: Composite Figures

Bill is painting his basement floor.

The dimensions are:

If one can of paint will cover 3.5 m^2 , and each can of paint costs $\$15.25$, what is his total cost including 15% GST and PST?



a) Determine the total area.

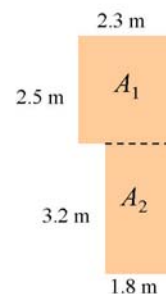

b) If one can of paint covers 3.5 m^2 , how many cans of paint will he need?



c) If one can of paint costs $\$15.25$, what is his total cost including 15% GST and PST?



Shelly wants to make curtains to cover her decorative window.

In order to hem the curtains she will add 10 cm to each edge.

If 1 m^2 of curtain material cost $\$2.20$, how much will it cost to make the curtains including 15% GST and PST?

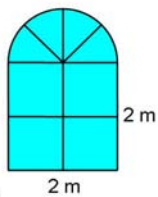

a) Determine area of semi-circle.

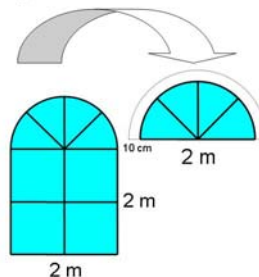

b) Determine area of the square.

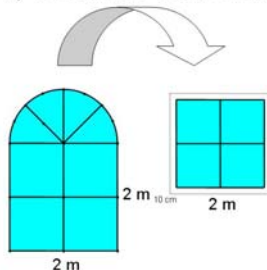

c) If 1 m^2 of material costs $\$2.20$, determine the total cost of the curtains including taxes?

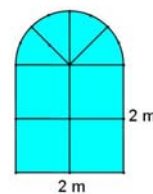

1.4.3: Exploring Composite Shapes

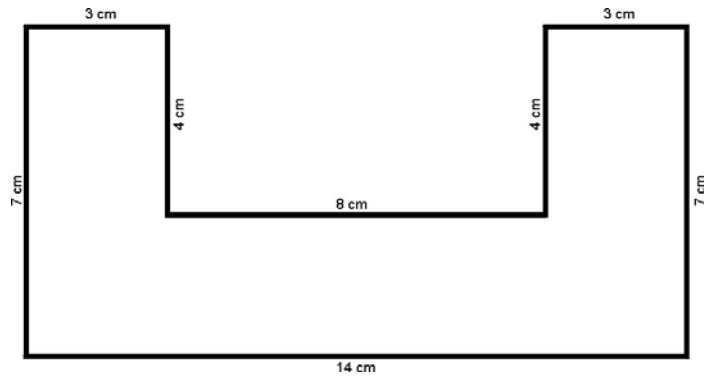

Shape Divisions	Area Calculations

1.4.4: Use What You Know

Knowledge and Skills

Calculate the area of the given circle.

Show your work.

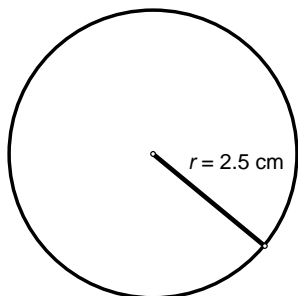

Hint: $A = \pi r^2$

Reasoning and Proving

Westview School has a track.

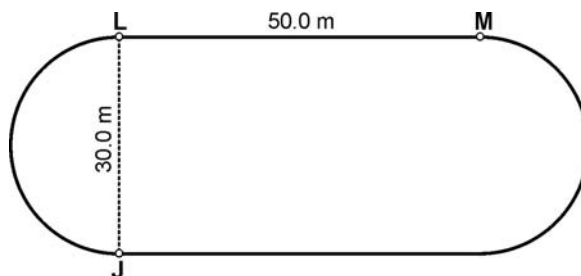

You want to run 2 km every day. Determine how many times you have to go around the track.

Show your work.

Communicating

Gemma wants to tile her bathroom counter with mini tiles. She needs to determine the area of her counter space. Explain with words, diagrams, and symbols how she should determine the area.

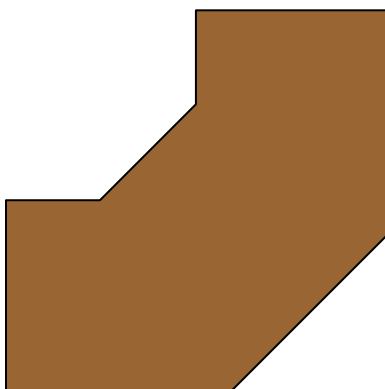

Connecting

This figure has a radius of r units.

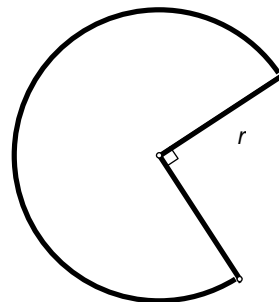

Which of the following formulas could be used to determine the perimeter?

- a) $2\pi r - \frac{1}{4} + r + r$ b) $0.75\pi r^2$
 c) $\frac{3}{4}(2\pi r) + r + r$ d) $2\pi r - \frac{1}{4}$

Give reasons for your answer.

1.4.5: Frayer Model

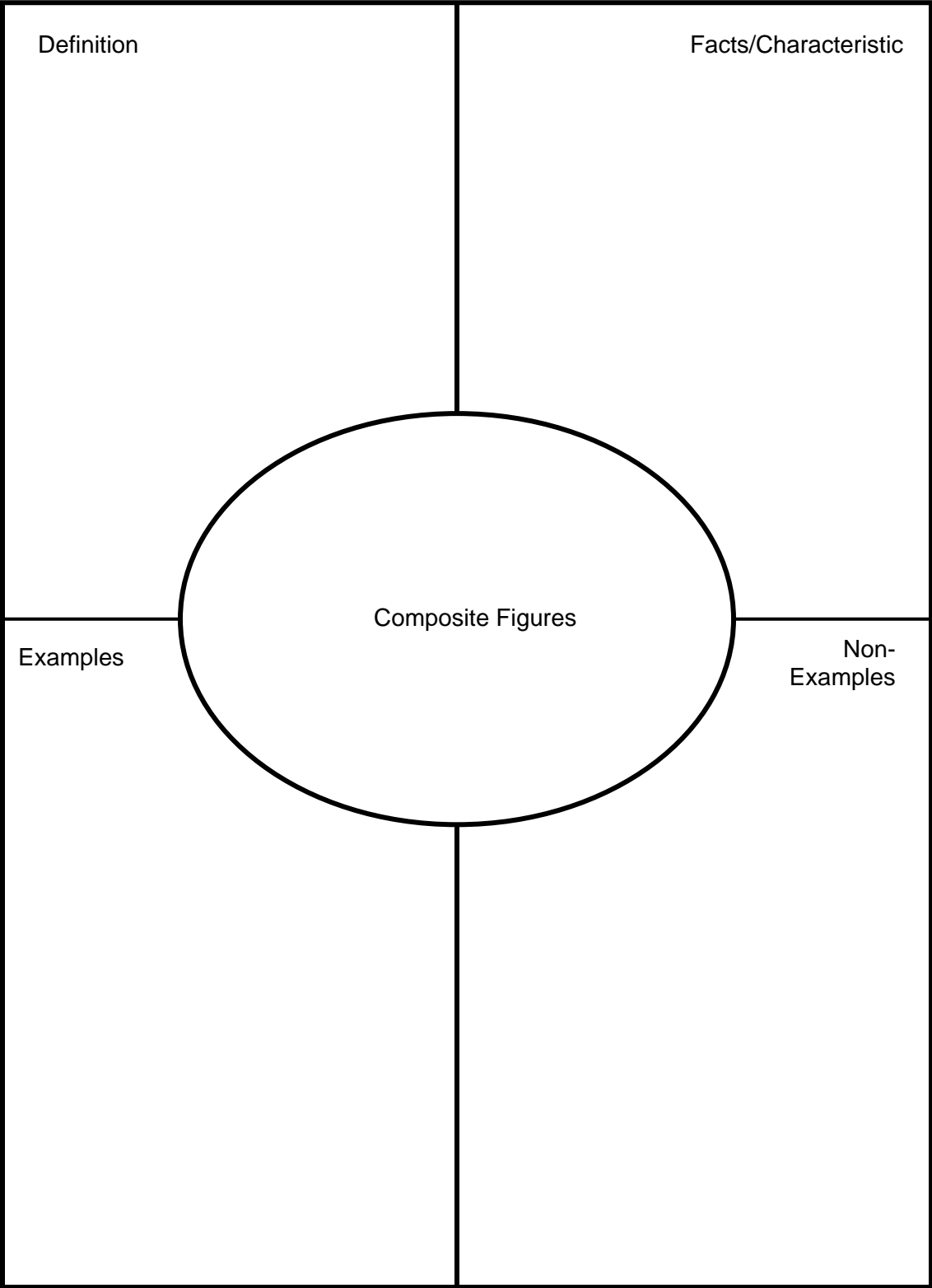

Composite Figures

(Presentation software file)

[CompositeFigures.ppt.](#)

1

Composite Figures
Pieces of the Whole

2

Bill is painting his basement floor.
The dimensions are:



If one can of paint will cover 3.5 m^2 , and each can of paint costs \$15.25, what is his total cost including 15% GST and PST?

3

a) Determine the total area.

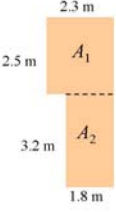

$$A_{\text{total}} = A_1 + A_2$$

$$A = 2.3 \times 2.5 + 3.1 \times 1.5$$

$$A = 5.75 + 4.65$$

$$A = 10.4 \text{ m}^2$$

4

b) If one can of paint covers 3.5 m^2 , how many cans of paint will he need?

$$\text{Number of cans} = \frac{10.4 \text{ m}^2}{3.5 \text{ m}^2/\text{can}}$$

$$\text{Number of cans} = 2.97$$

He will need *three* cans of paint.

5

c) If one can of paint costs \$15.25, what is his total cost including 15% GST and PST?

Paint cost: $3 \times \$15.25 = \45.75
Taxes: $= 0.15 \times \$45.75 = \6.86

Total cost: \$52.61

6

Shelly wants to make curtains to cover her decorative window.

In order to hem the curtains she will add 10 cm to each edge.

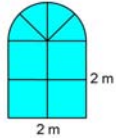

If 1 m^2 of curtain material cost \$2.20, how much will it cost to make the curtains including 15% GST and PST?

7

a) Determine area of semi-circle.

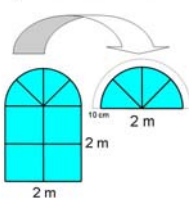

The radius for material is 1.10 metres.

$$A = \pi r^2 + 2$$

$$A = \pi(1.10)^2 + 2$$

$$A \approx 3.80 + 2$$

$$A \approx 1.90 \text{ m}^2$$

8

b) Determine area of the square.

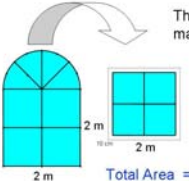

The length of the sides of material is 2.20 metres.

$$A = l \times w$$

$$A = (2.20)(2.20)$$

$$A = 4.84 \text{ m}^2$$

Total Area = Semi Circle + Square
 $= 1.90 + 4.84$
 $= 6.74 \text{ m}^2$ or 7 m^2

9

c) If 1 m^2 of material costs \$2.20, determine the total cost of the curtains including taxes?

Material: $\$2.20 \times 7 = \15.40
Taxes: $\$15.40 \times 0.15 = \2.31

Total Cost: \$17.71



Math Learning Goals

- Connect the geometric representation of the Pythagorean theorem to the algebraic representation $a^2 + b^2 = c^2$.
- Relate their understanding of inverse operations to squares and square roots.

Materials

- rope
- overhead projector
- BLM 1.5.1, 1.5.2, 1.5.3, 1.5.4, 1.5.5
- newsprint, glue sticks
- computer/data projector

Assessment Opportunities

Minds On ...

Whole Class → Demonstration and Discussion

Tell the story of the rope stretchers (BLM 1.5.1). Choose three students to act it out, manipulating a rope to ensure they have created a right-angled triangle. Ask the class for ways to ensure the triangle created is a right-angled triangle.

[Pythagorean Theorem.ppt](#)

Action!

Pairs or Small Groups → Investigation

Distribute one A card and one B card to each pair/group (BLM 1.5.2). Students work through Part A (BLM 1.5.3), recording their data and observations on the worksheet. Guide students' construction in question 2 (BLM 1.5.4) using a overhead projector. At the end of Part A, they combine with another group to complete question 4 (BLM 1.5.3).

Learning Skills/Observation/Checklist: Observe students' groupwork skills.

Whole Class → Discussion and Summarizing

Students enter group data on two master lists according to triangle type – right-angled triangle, non-right-angled triangle – and copy data onto their own table on BLM 1.5.3 (Part B). Lead a class discussion on question 6 to bring out patterns (square of A plus the square of B always equals the square of C, only in right-angled triangles).

Guide the students from verbal model to algebraic model. Students record it on BLM 1.5.3. Stress that this relationship only exists in right-angled triangles.

Consolidate Debrief

Whole Class → Presentation

Show the electronic presentation on Pythagorean theorem to consolidate learning. Walk students through BLM 1.5.5. Discuss inverse operations and apply them to squares and square roots. Clarify the task on BLM 1.5.5. Students share their responses.

[Word Wall hypotenuse](#)

Concept Practice

Home Activity or Further Classroom Consolidation

Imagine you are a rope stretcher. Find two different combinations, not in the class list, that would create right-angled triangles. Explain how you know that the triangles are right-angled.

1.5.1: The Rope Stretchers

In ancient Egypt, mathematicians developed many useful ideas for everyday living. One example was used by Egyptian farmers. Each year the Nile River flooded, leaving behind a stretch of fertile land where the Egyptians grew their crops of barley and emmer wheat. But, when the river flooded, the boundaries of the fields were lost and had to be accurately “redrawn.”

Egyptian surveyors or “rope stretchers” used lengths of ropes with equally spaced knots tied in them to measure land boundaries. When two fields bordered one another, the rope stretchers had to measure a right angle to form the corners of the



fields. The establishment of boundaries was also important because the area of the land determined the amount of taxes, and the scribes kept the accounts for taxation.

Excerpted from http://www.edhelper.com/ReadingComprehension_35_193.html
July 26, 2005

1.5.2: Group Investigation Cards

Note: Cut out and distribute one Card A and one Card B to each group. Some groups may receive the same A or B cards, but try to ensure that no group has the same two cards.

Card A1 Three squares with sides of: 3, 4, 5 units	Card A2 Three squares with sides of: 6, 8, 10 units	Card A3 Three squares with sides of: 9, 12, 15 units
Card A4 Three squares with sides of: 5, 12, 13 units	Card A1 Three squares with sides of: 3, 4, 5 units	Card A2 Three squares with sides of: 6, 8, 10 units
Card A3 Three squares with sides of: 9, 12, 15 units	Card A4 Three squares with sides of: 5, 12, 13 units	Card A1 Three squares with sides of: 3, 4, 5 units
Card A2 Three squares with sides of: 6, 8, 10 units	Card A3 Three squares with sides of: 9, 12, 15 units	Card A4 Three squares with sides of: 5, 12, 13 units

1.5.2: Group Investigation Cards (continued)

<p>Card B1</p> <p>Three squares with sides of: 3, 5, 7 units</p>	<p>Card B2</p> <p>Three squares with sides of: 6, 6, 10 units</p>	<p>Card B3</p> <p>Three squares with sides of: 4, 7, 9 units</p>
<p>Card B4</p> <p>Three squares with sides of: 3, 8, 9 units</p>	<p>Card B1</p> <p>Three squares with sides of: 3, 5, 7 units</p>	<p>Card B2</p> <p>Three squares with sides of: 6, 6, 10 units</p>
<p>Card B3</p> <p>Three squares with sides of: 4, 7, 9 units</p>	<p>Card B4</p> <p>Three squares with sides of: 3, 8, 9 units</p>	<p>Card B1</p> <p>Three squares with sides of: 3, 5, 7 units</p>
<p>Card B2</p> <p>Three squares with sides of: 6, 6, 10 units</p>	<p>Card B3</p> <p>Three squares with sides of: 4, 7, 9 units</p>	<p>Card B4</p> <p>Three squares with sides of: 3, 8, 9 units</p>

1.5.3: Right or Not?

Group member names:

Part A: Group Work

1) Record the three side lengths:

Card A _____

Card B _____

2) Follow the instructions on the overhead to construct your two triangles.
Draw a labelled diagram of the triangle created by the three squares. Show side lengths.

Card A

Card B

3) Complete the table:

Card	Square with side a	Square with side b	Largest Square with side c	Type of Triangle

4) Share your data with another group. What observations can you make about the data?

1.5.3: Right or Not? (continued)

Part B: Class Work

5) Complete the data table:

Group	Area of Square with side a	Area of Square with side b	Area of Largest Square with side c	Type of Triangle

6) What other observations can you make about the class data set?

Verbal Model:

Algebraic Model:

1.5.4: Squares and Triangles

Instructions for each card

- 1) Create three squares, one for each of the side lengths given on the card you received.
- 2) Cut out the squares.
- 3) Position the three squares on the newsprint so that the three squares create a triangle in the middle (see diagram).
- 4) Glue the squares into position, carefully lining up the corners. Do not allow the corners to overlap or have gaps.
- 5) Label the area of each square inside the square.
- 6) Trace the sides of the triangle in marker.
- 7) Measure the angles in the triangle and record the measures on the diagram.

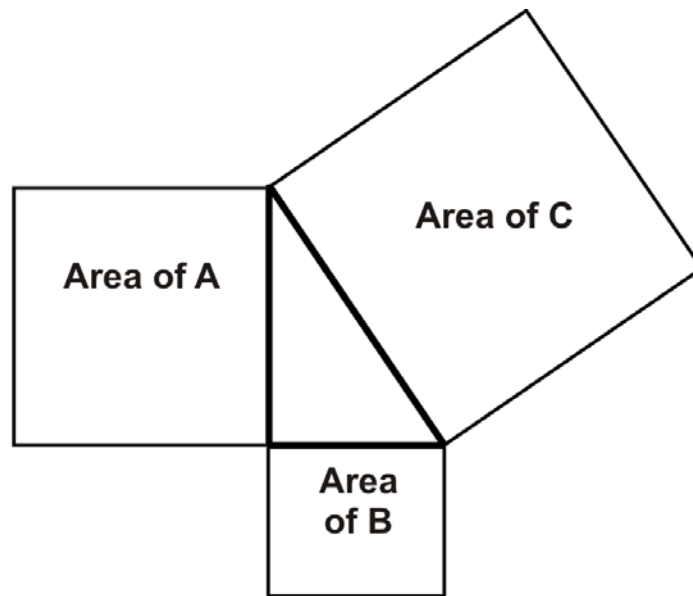

1.5.5: Pythagorean Theorem

1

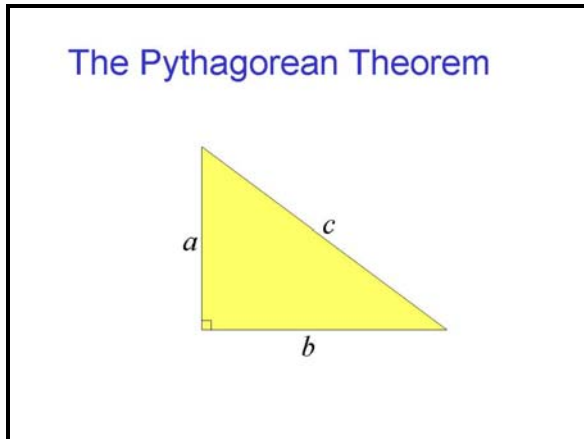

2

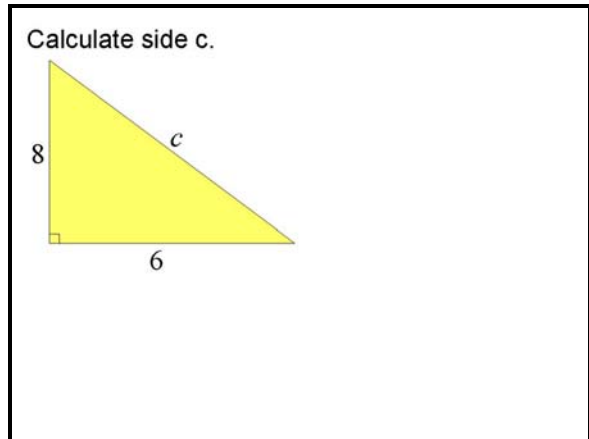

3

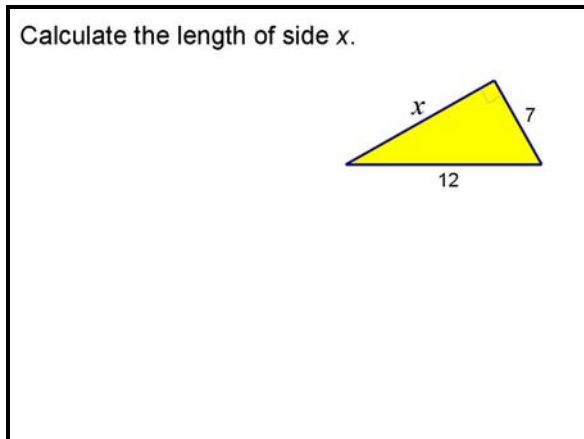

4

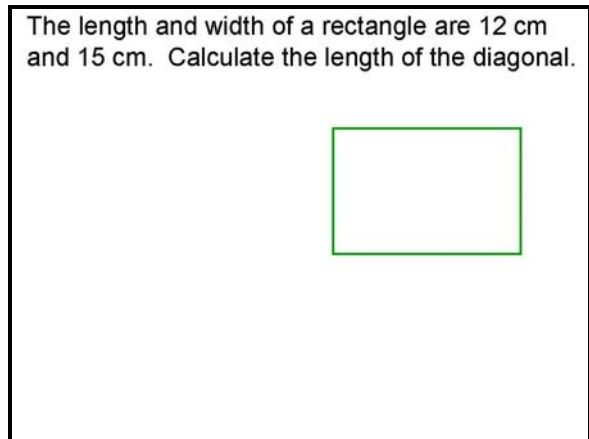

5

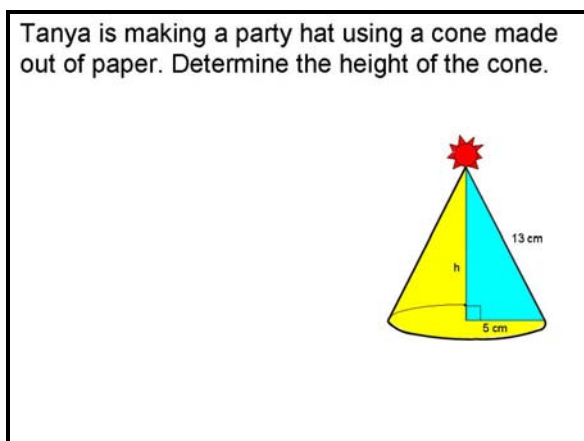

The Pythagorean Theorem

(Presentation software file)

[PythagoreanTheorem.ppt.](#)

1

The Pythagorean Theorem

$$a^2 + b^2 = c^2 \quad \text{OR}$$

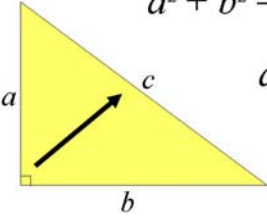
$$a^2 = c^2 - b^2$$

Which side is the hypotenuse?

The right angle points to the hypotenuse.
It's the side labelled "c".

2

Calculate side c.

$$c^2 = a^2 + b^2$$

$$c^2 = 8^2 + 6^2$$

$$c^2 = 64 + 36$$

$$c^2 = 100$$

$$c = \sqrt{100}$$

$$c = 10$$

When calculating the hypotenuse, we add the area of the squares of the other two sides.

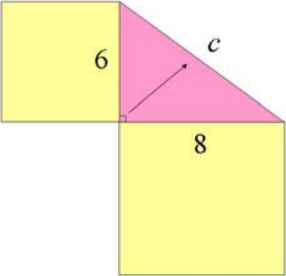

3

Calculate the length of side x.

$$b^2 = c^2 - a^2$$

$$x^2 = 12^2 - 7^2$$

$$x^2 = 144 - 49$$

$$x^2 = 95$$

$$x = \sqrt{95}$$

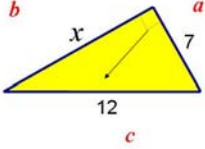
$$x = 9.7$$

When calculating a side, we determine the *difference* of the area of the square of the hypotenuse and the area of the square of the known side.

4

The length and width of a rectangle are 12 cm and 15 cm. Calculate the length of the diagonal.

$$c^2 = a^2 + b^2$$

$$d^2 = 15^2 + 12^2$$

$$d^2 = 225 + 144$$

$$d^2 = 369$$

$$d = \sqrt{369}$$

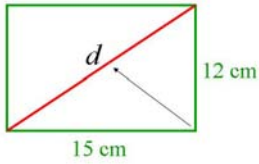
$$d = 19.2 \text{ cm}$$

5

Tanya is making a party hat using a cone made out of paper. Determine the height of the cone.

$$b^2 = c^2 - a^2$$

$$h^2 = 13^2 - 5^2$$

$$h^2 = 169 - 25$$

$$h^2 = 144$$

$$h = \sqrt{144}$$

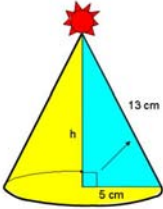
$$h = 12 \text{ cm}$$



75 min

Math Learning Goals

- Solve 2-D and 3-D problems using the Pythagorean theorem.
- Substitute into and evaluate algebraic expressions involving exponents.

Materials

- BLM 1.6.1, 1.6.2
- relational solids
- BLM 1.6.3 (Teacher)

Assessment Opportunities

Minds On ...

Pairs → Pair/Share/Conference

Students share their home activities, checking for accuracy.

Pairs → Practice

Pairs complete three problems from each column on BLM 1.6.1, using the peer coaching model (one student records as the other verbalizes).

Circulate to check progress and give feedback.

Individual → Quiz

Each student individually completes the remaining problems in one of the columns. Collect for assessment.

Curriculum Expectations/Quiz/Scoring Guide: Assess students' accuracy in using the theorem.

Action!

Pairs → Investigation

Briefly outline the activity (BLM 1.6.2). Give each pair a different set of pyramid and cone dimensions (BLM 1.6.3).

Pairs work through BLM 1.6.2, using relational solids, if necessary.

Small Groups → Presentation

Pairs present their findings to another pair, sharing observations and conclusions regarding shapes with greater volume and preferred shape.

Consolidate Debrief

Whole Class → Anticipation Guide

Label two places in the room Agree and Disagree.

Students respond to the statement “The greatest volume was found in the pyramid,” by moving to their designated choice. Repeat with “The cone is the preferred shape.”

Discuss the considerations they used to make their decisions.

Home Activity or Further Classroom Consolidation

Respond to the following statement in your journal:

Your friend was away for today’s lesson. Write an email describing how to find the height of a pyramid or cone when given the dimensions. Provide your own example.

Concept Practice Reflection

1.6.1: Coach and Be Coached

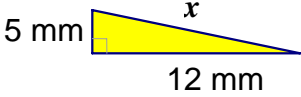
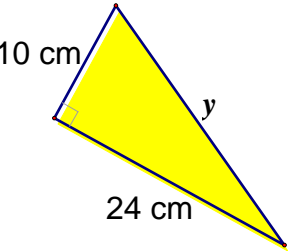
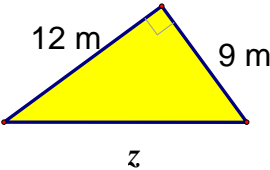
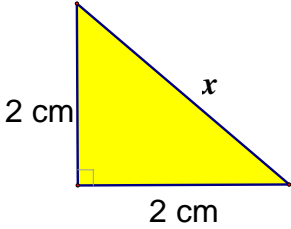
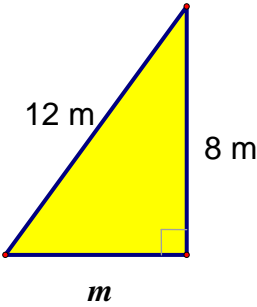
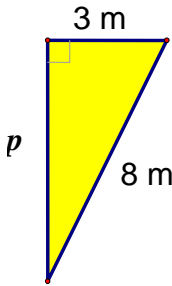
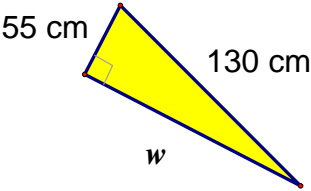
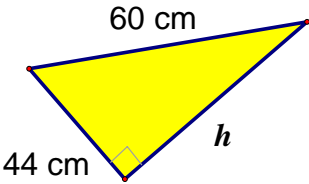
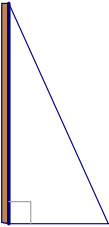
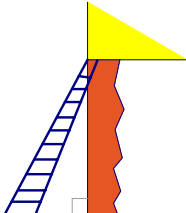
A coaches B	B coaches A
	
	
	
	
<p>A hydro pole casts a shadow that is 10 m long. A technician measures the wire that runs from the top of the pole to the end of the shadow and finds it to be 26 m. How tall is the pole?</p> 	<p>Don is building a loft in his garage. The ladder he is using extends to 10 metres. The loft is 8 m from the floor. How far away from the wall should he anchor the ladder?</p> 

1.6.2: The Container!

The Geobellies company wishes to make a new type of container for their product. The designer has created two containers: one the shape of a square-based pyramid, and the other a cone. Your job is to determine which container holds more.

- 1) Label the dimensions from your group card.

Pyramid

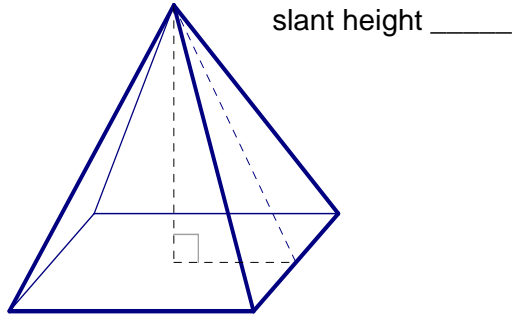

base length _____

Cone

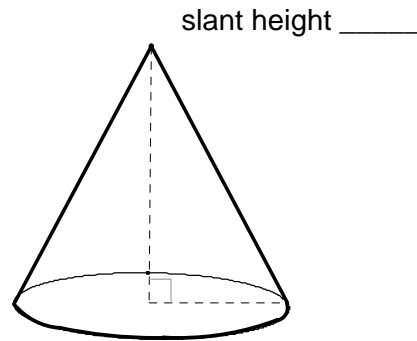

diameter _____

- 2) Discuss with your partner how you could find the height of each container.
- 3) Record your ideas using words, pictures, and symbols.
- 4) Determine the height of each container. Show all of your work.

1.6.2: The Container! (continued)

- 5) How much can each container hold? Show your work.
- 6) If the geobellies cost $\$0.005/\text{cm}^3$, how much will it cost to fill each container?
- 7) Identify the shape with the greater volume.
- 8) Make a recommendation for the preferred design shape. Provide at least two reasons for your choice.

Design Proposal

1.6.3: The Container! (Teacher)

Possible dimensions for The Container! (BLM 1.6.2)

	Pyramid		Cone	
	Base length	Slant height	Diameter	Slant height
1.	10.5 cm	5.6 cm	10.5 cm	5.6 cm
2.	12.4 cm	6.4 cm	12.4 cm	6.4 cm
3.	11.8 cm	6.0 cm	11.8 cm	6.0 cm
4.	9.9 cm	6.0 cm	9.9 cm	6.0 cm
5.	10.3 cm	5.7 cm	10.3 cm	5.7 cm
6.	12.1 cm	6.8 cm	12.1 cm	6.8 cm
7.	11.5 cm	5.9 cm	11.5 cm	5.9 cm
8.	10.4 cm	5.8 cm	10.4 cm	5.8 cm
9.	10.2 cm	5.9 cm	10.2 cm	5.9 cm
10.	11.7 cm	6.1 cm	11.7 cm	6.1 cm
11.	12.2 cm	7.1 cm	12.2 cm	7.1 cm
12.	9.8 cm	5.3 cm	9.8 cm	5.3 cm

Unit 1 Test: Describing Relationships in Measurement

Name: _____

A communication level will be assigned based on use of mathematical conventions and clarity of explanations.

- (2) 1. For each of the following triangles, show your substitution into the Pythagorean relationship.

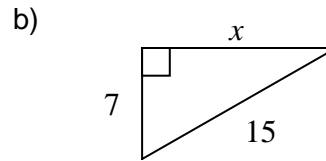
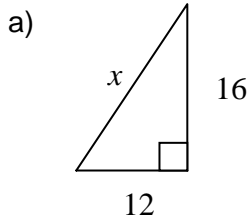

- (3) 2. Find the area of the shaded region.

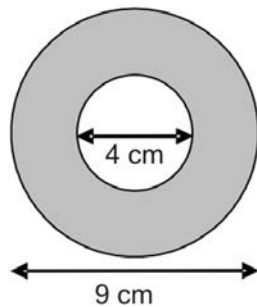

- (6) 3. Consider the track below.

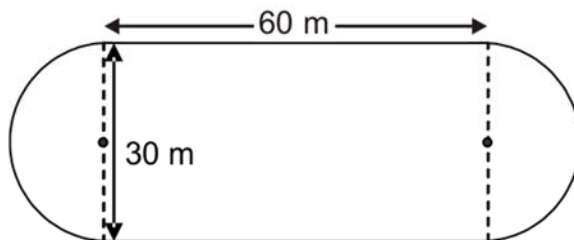

- a) Find the perimeter of the field. b) Find the area of the field.

(3) 4. Frozen ice cream treats are sold in cone-shaped containers. The containers are 12 cm high and have a 5 cm diameter. Determine the volume of one ice cream treat container.

(3) 5. A snowball has a diameter of 7 cm. Determine the volume of the snowball.

(2) 6. A new park is constructed in your neighbourhood. The park is to be fully fenced and sodded. How much fencing and sod are required?

