

Unit 10

Volume of Right Prisms

Grade 7

Lesson Outline

Big Picture

Students will:

- develop and apply the formula: Volume = area of the base \times height to calculate volume of right prisms;
- understand the relationship between metric units of volume and capacity;
- understand that various prisms have the same volume.

Day	Lesson Title	Math Learning Goals	Expectations
1	Exploring the Volume of a Prism	<ul style="list-style-type: none"> • Develop and apply the formula for volume of a prism, i.e., area of base \times height. • Relate exponential notation to volume, e.g., explain why volume is measured in cubic units. 	7m17, 7m34, 7m36, 7m40 CGE 5d, 5e
2	Metric measures of Volume <i>(lesson not included)</i>	<ul style="list-style-type: none"> • Determine the number of cubic centimetres that entirely fill a cubic decimetre, e.g., Use centimetre cubes to determine the number of cm^3 that cover the base. How many layers are needed to fill the whole dm^3? • Determine how many dm^3 fill a m^3 and use this to determine how many cm^3 are in a m^3. • Solve problems that require conversion between metric units of volume. 	7m35, 7m42 CGE 3b, 4a
3	Metric Measures of Capacity and Mass <i>(lesson not included)</i> (See Metric Capacity and Mass – My Professional Practice)	<ul style="list-style-type: none"> • Explore the relationship between cm^3 and litres, e.g., cut a 2-litre milk carton horizontally in half to make a 1-litre container that measures $10\text{ cm} \times 10\text{ cm} \times 10\text{ cm}$. This container holds 1 litre or 1000 cm^3. • Determine that 1 cm^3 holds 1 millilitre. • Solve problems that require conversion between metric units of volume and capacity. 	7m35, 7m42 CGE 3b, 4a
4	Volume of a Rectangular Prism	<ul style="list-style-type: none"> • Determine the volume of a rectangular prism, using the formula Volume = area of the base \times height. • Solve problems involving volume of a rectangular prism. 	7m34, 7m40, 7m42 CGE 4b, 4c
5	Volume of a Triangular Prism	<ul style="list-style-type: none"> • Determine the volume of a triangular prism, using the formula Volume = area of the base \times height. • Solve problems involving volume of a triangular prism that require conversion between metric measures of volume. 	7m34, 7m40, 7m42 CGE 3c, 5d
6	Volume of a Right Prism with a Parallelogram Base	<ul style="list-style-type: none"> • Determine the volume of a parallelogram-based prism, using two methods. • Determine that the volume of the parallelogram-based prism can be calculated, using the formula: Volume = area of the base \times height. • Solve problems involving volume of a parallelogram-based prism. 	7m35, 7m40, 7m42 CGE 5f
7	Volume of a Trapezoid-Based Prism	<ul style="list-style-type: none"> • Determine the volume of a trapezoidal-based prism. • Solve problems involving volume of a trapezoidal-based prisms. 	7m23, 7m34, 7m38, 7m40, 7m42 CGE 5f

Day	Lesson Title	Math Learning Goals	Expectations
8	Volume of Other Right Prisms	<ul style="list-style-type: none"> Determine the volume of right prisms (with bases that are pentagons, hexagons, quadrilaterals, composite figures), using several methods. 	7m23, 7m34, 7m40, 7m42 CGE 3b
9	Linking Surface Area and Volume	<ul style="list-style-type: none"> Apply volume and area formulas to explore the relationship between triangular prisms with the same surface area but different volumes. Estimate volumes. 	7m23, 7m42 CGE 4c, 5a
10	Surface Area and Volume of Right Prisms <i>GSP® 4 file:</i> PaperPrism.gsp	<ul style="list-style-type: none"> Investigate the relationship between surface area and volume of rectangular prisms. 	7m23, 7m42 CGE 4c, 5a
11	Summative Performance Tasks <i>(lesson not included)</i>	<ul style="list-style-type: none"> Assess students' knowledge and understanding of volume of prisms with polygon bases. 	CGE 3a, 3c
12	Summative Performance Task <i>(lesson not included)</i>	<ul style="list-style-type: none"> Skills test 	CGE 3a, 3c

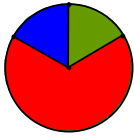

Math Learning Goals

- Develop and apply the formula for volume of a prism, i.e., area of base \times height.
- Relate exponential notation to volume, e.g., explain why volume is measured in cubic units.

Materials

- linking cubes
- BLM 10.1.1, 10.1.2
- isometric dot paper (BLM 8.8.1)

Assessment Opportunities

Minds On... Whole Class \rightarrow Guided Instruction

Show a cube and ask: If the length of one side is 1 unit:

- What is the surface area of one face? (1 unit^2)
- What is the volume? (1 unit^3)
- Why is area measured in square units?
- Why is volume measured in cubic units?

Using a “building tower” constructed from linking cubes, lead students through a discussion based on the model:

- Why is this a right prism?
- What is the surface area of the base?
- What is the height of the building?

Count the cubes to determine the volume of the building.

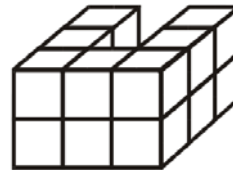

A prism has at least one pair of congruent, parallel faces.

Action! Pairs \rightarrow Investigation

Invite students to ask clarifying questions about the investigation (BLM 10.1.1). Students create several more irregular prisms of various sizes, using BLM 10.1.1, Building Towers. Students display their findings in the table.

After investigating the problem with several samples, state a general formula for the volume of a prism:

$$\text{Volume} = \text{area of the base} \times \text{height}$$

Students test their formula for accuracy by constructing two other towers.

Curriculum Expectations/Oral Questioning/Anecdotal Note: Assess students’ understanding of the general formula $\text{Volume} = \text{area of the base} \times \text{height}$.

Consolidate Debrief Whole Class \rightarrow Student Presentation

As students present their findings, summarize the results of the investigation on a class chart.

Orally complete a few examples, calculating the volume of prisms given a diagram.

Reinforce the concept of cubic units.

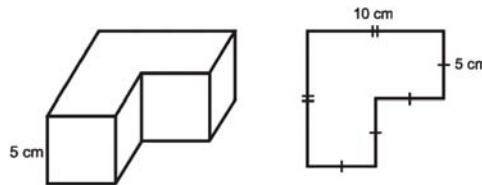

Home Activity or Further Classroom Consolidation

A prism has a volume of 24 cm^3 . Draw prisms with this volume. How many possible prisms are there with a volume of 24 cm^3 with sides whose measurements are whole numbers?

*Concept Practice
Application
Skill Drill*

If students use decimal and fractional measures, an infinite number of prisms is possible.

10.1.1: Building Towers

Name:

Date:

Each tower pictured here is a prism. Build each prism and determine the volume of each building by counting cubes.

Tower A

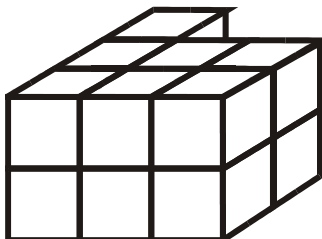

Tower B

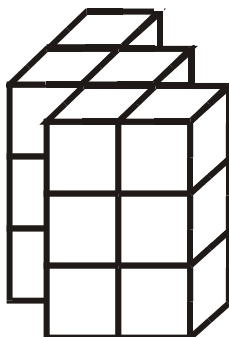

Tower C

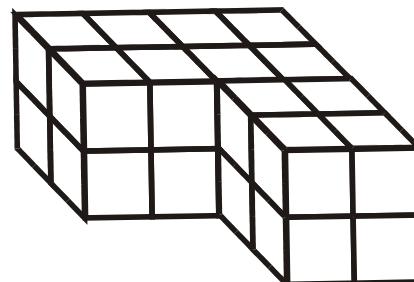

- Complete the table of measures for each tower:

Tower	Area of Base	Height of Tower	Volume (by counting cubes)
A			
B			
C			

- What relationship do you notice between volume, area of the base, and height?
- State a formula that might be true for calculating volume of a prism when you know the area of the base and the height of the prism.
- Test your formula for accuracy by building two other prism towers and determining the volume. Sketch your towers. Show calculations on this table.

Tower	Area of Base	Height	Volume (by counting cubes)	Volume (using your formula)
D				
E				

- Explain why your formula is accurate.



Math Learning Goals

- Determine the volume of a triangular prism using the formula
Volume = area of the base × height.
- Solve problems involving volume of a triangular prism that require conversion between metric measures of volume.

Materials

- models of triangular prisms
- BLM 10.5.1

Assessment Opportunities

Minds On... Whole Class → Sharing

Students share their sketches of prisms with volumes 27 cm^3 and 48 cm^3 and the responses to the questions. Students should use the term *factors* when explaining the relationship of the measures. Make a list of rectangular prisms that can be generated by several different sets of measurements. Discuss the relationship of these measures to the factors of a number.

Whole Class → Discussion

Using concrete samples of a triangular prism, ask students:

- What can be altered in the volume of a prism formula to make the formula specific for a triangular prism?
- Will the volume be the same or different when the prism is oriented vertically or horizontally?
- What do we need to think about when applying the volume formula to a triangular prism?

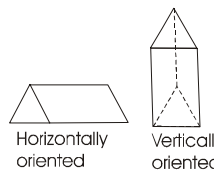

For any prism:
 $V = \text{area of base} \times \text{height}$

For triangular prisms:
 $V = \frac{1}{2} bh \times H$

When calculating the volume of a triangular prism, its base is one of the triangles, not one of the rectangles.

Some students may need the physical model to assist their understanding.

Action! Pairs → Investigation

Students use a triangular prism to develop a formula specific to their prism (based on the general formula of Volume = area of the base × height.) They investigate how to use this formula to calculate volume of several horizontally and vertically oriented prisms, and show their calculations to justify their conclusions.

Curriculum Expectations/Oral Questioning/Anecdotal Note: Assess students' understanding of the general formula Volume = area of the base × height.

Consolidate Debrief Whole Class → Reflection

Students share their investigation findings. Focus discussion on the need to identify the triangular face as the “base” when using the formula $V = \text{area of base} \times \text{height}$ for a triangular prism. Connect this discussion to the idea of stacking triangles either vertically or horizontally to generate the triangular prism.

Discuss the need for h and H in the formula for volume: h is perpendicular to b and refers to the triangle’s height, H is the perpendicular distance between the triangular bases. Discuss each of these in relationship to rectangular prisms. If students understand that all right prisms have a Volume = (area of base) (height) they should not get confused by multiple formulas.

Students complete BLM 10.5.1.

When assigning triangular prism questions from a textbook, ensure that no questions require the use of the Pythagorean theorem.

Home Activity or Further Classroom Consolidation

Concept Practice

Sketch and label the dimensions of a triangular prism whose whole number dimensions will produce a volume that is:

- a) an even number b) an odd number c) a decimal value

Explain your thinking in each case.

10.5.1: Volume of Triangular Prisms

Show your work using good form and be prepared to tell how you solved the problem.

1. Determine the volume of the piece of cheese.
Create a problem based on the volume.

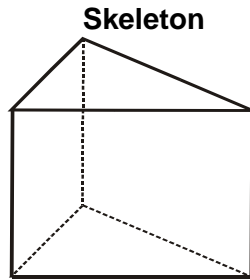
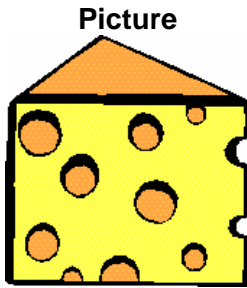

H = height of prism = 5.0 cm
length of rectangle = 6.3 cm

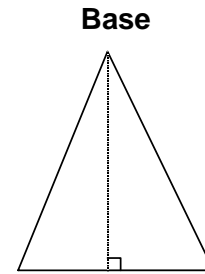

height of triangle = 6.0 cm
base of triangle = 4.0 cm

2. Determine the volume of the nutrition bar.
Create a problem based on the volume.

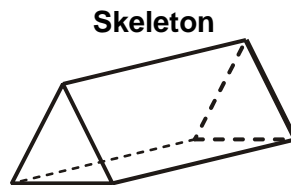
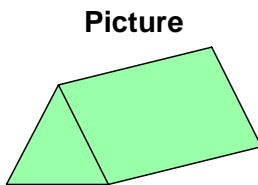

Length of rectangle = 5.0 cm

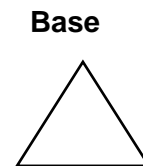

Equilateral triangle with:
height = 3.0 cm
base = 3.5 cm

10.5.1: Volume of Triangular Prisms (continued)

3. Determine the volume of air space in the tent.
The front of the tent has the shape of an isosceles triangle.

Create a problem based on the volume.

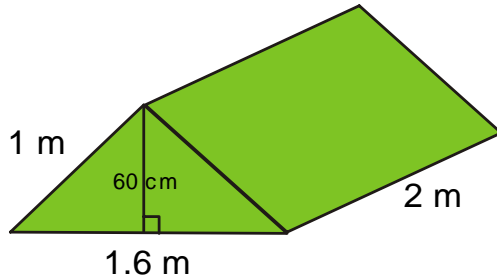

4. a) If you could only have 1 person per 15 m^3 to meet fire safety standards, how many people could stay in this ski chalet?

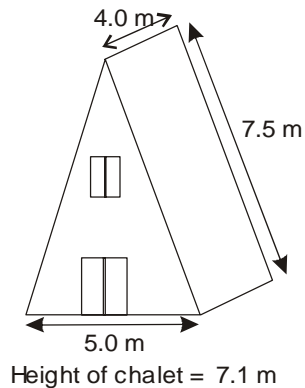

Hint:

Think about whether the height of the chalet is the same as the height of the prism.

Which measurements are unnecessary for this question?

- b) How much longer would the chalet need to be to meet the safety requirements to accommodate 16 people?

**Math Learning Goals**

- Determine the volume of a parallelogram-based prism using two methods.
- Determine that the volume of the parallelogram-based prism can be calculated using the formula: Volume = area of the base \times height.
- Solve problems involving volume of a parallelogram-based prism.

Materials

- BLM 10.6.1
- calculators

Minds On...**Whole Class \rightarrow Demonstration**

Display two triangular prisms with congruent bases, e.g., use polydron materials or two triangular prism chocolate bars, or two triangular prisms cut from the net on BLM 10.6.1.

Students measure and calculate the volume of one of the prisms. Demonstrate how the two triangular prisms can be fitted together to make a parallelogram-based prism.

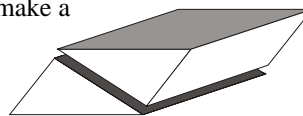
**Assessment Opportunities**

Seeing the two triangular prisms physically fitted together to make a parallelogram-based prism can help students visualize the various shapes and build their spatial thinking.

Two methods:
a) Multiply the triangular prism's volume by 2
b) Use the volume formula: area of the base \times height

Action!**Pairs \rightarrow Investigation**

Students respond to the question: How can the volume of the parallelogram-based prism be determined, knowing the volume of one triangular prism?

They find a second method for calculating the volume of a parallelogram-based prism and compare the two methods.

They verify that their findings are always true by creating several other parallelogram-based prism measurements.

The volume of a parallelogram-based prism can always be determined by decomposing it into two triangular prisms. (The formula Volume = area of base \times height will determine the volume for any right prism.)

Consolidate Debrief**Whole Class \rightarrow Discussion**

Debrief the students' findings to help them understand that the volume of a parallelogram-based prism can be determined by determining the area of the parallelogram base, which is composed of two congruent triangles and is $(b \times h)$ multiplied by the height (H) of the prism. The volume of the parallelogram-based prism can also be determined using the formula:

Volume = area of the base \times height of the prism.

Model the solution to an everyday problem that requires finding the volume and capacity of a parallelogram-based prism.

*Concept Practice***Home Activity or Further Classroom Consolidation**

- Write a paragraph in your journal: There is one formula for all right prisms. It is... Here are some examples of how it is used....

OR

- Complete the practice questions.

Curriculum Expectations/ Demonstration/ Marking Scheme:
Assess students' understanding of the general formula for right prisms.

Provide students with appropriate practice questions.

10.6.1: Triangular Prism Net

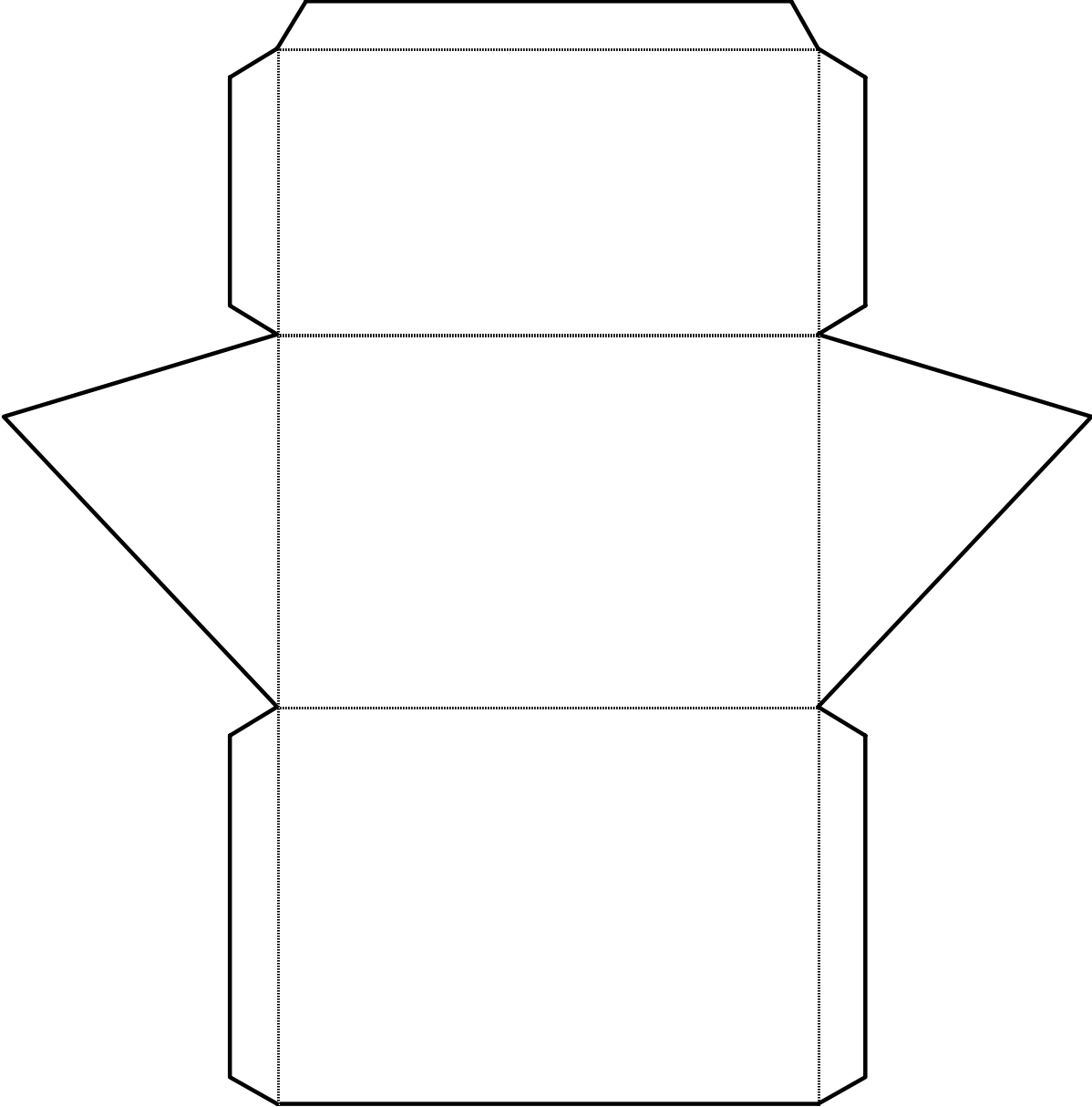

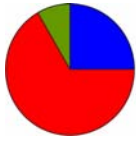

Math Learning Goals

- Determine the volume of a trapezoidal-based prism using several methods for using the formula $\text{Volume} = \text{area of the base} \times \text{height}$ to determine if there is a relationship.
- Solve problems involving volume of a trapezoidal-based prisms.

Materials

- BLM 10.7.1

Minds On...

Whole Class → Review

Review the definition and characteristics of a trapezoid. Recall methods for calculating the area of a trapezoid.

Action!

Pairs → Investigation

Students complete the investigation:

Can the formula $\text{Volume} = \text{area of the base} \times \text{height}$ of the prism be used to determine the volume of trapezoid-based prisms instead of decomposing the trapezoid?

Investigate to determine the volume of a trapezoid-based right prism by decomposing the trapezoid into triangles and rectangles, using different decompositions.

Compare the solutions from the decomposition method to the volume calculated using the standard formula.

Write your findings in a report. Include diagrams and calculations.

Prompt students who are having difficulty decomposing the trapezoid by suggesting some of these possibilities:

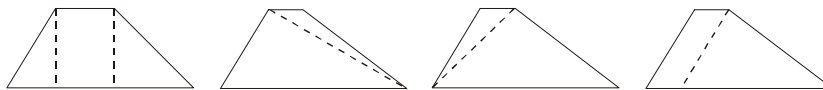

Problem Solving/Application/Checkbric: Asses students' problem solving techniques, as well as their communication in the report.

Assessment Opportunities

The most common ways to decompose a trapezoid are into:

- one rectangle and two triangles
- two triangles
- one parallelogram and one triangle.

Students may choose to do the calculations using a 2-D diagram of the trapezoid. Other students may need to build the 3-D shapes to visualize the solution.

Consolidate Debrief

Whole Class → Discussion

Discuss the need for h and H in the formula and the importance of the order of operations.

Focus the discussion on the fact that the standard formula $\text{Volume} = \text{area of the base} \times \text{height}$ of the prism always works for right prisms. Volume can also be calculated by decomposing into composite prisms.

$$V = \text{area of base} \times \text{height}$$

$$V = \left[\frac{(a + b)h}{2} \right] (H)$$

Order of operations is important to calculate correctly.

Concept Practice

Home Activity or Further Classroom Consolidation

Complete worksheet 10.7.1.

10.7.1: Designing a Box

A local pet food company wishes to package their product in a box. The preliminary box design is shown on the left.

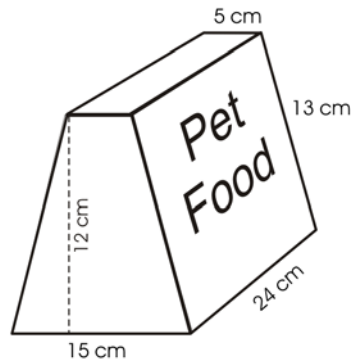

Box A

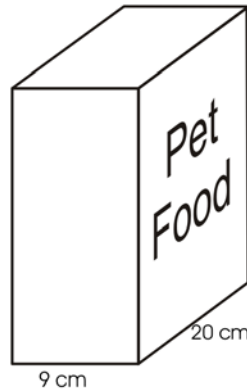

Box B

1. Determine the volume of the box on the left. Verify your calculation using an alternate method.

2. Box B has the same volume as Box A. What is the height of Box B? Explain how you know.

3. Design a new box, Box C, with the same volume as the two boxes above.

Alternate

Build Box A and B. Be sure B has the same volume as A. Fill them up to check for equal volume.

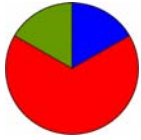

Math Learning Goals

- Determine the volume of right prisms (with bases that are pentagons, hexagons, quadrilaterals, composite figures), using several methods.

Materials

- BLM 10.8.1

Assessment Opportunities

Minds On... Whole Class → Presentations

Students discuss the solution to the homework problem. Some students share their design for Box C. The class checks the dimensions for correctness.

If students built Boxes A and B, have them explain their method and prove that their volumes were the same.

Have some of the previously constructed figures available for student reference.

Action! Whole Class → Brainstorming

Use a mind map to brainstorm a list of other possible shapes that could form the base of a right prism.

Students sketch the 2-D shapes on the board – pentagons, hexagons, quadrilaterals, and composite figures.

Learning Skills (Class Participation)/Observation/Mental Note: Assess students' participation during the brainstorm.

Pairs → Practice

Students decompose the shapes displayed into triangles and rectangles. They discuss how they would determine the area of the shape of the base in order to calculate the volume of that prism, e.g., $V = \text{area of base} \times \text{height}$; decompose the prism into other prism shapes with triangular and rectangular bases.

Pairs → Problem Solving

Students complete BLM 10.8.1.

Composite shapes for the base of the prism.

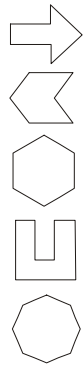

Consolidate Debrief Whole Class → Presentation

Students present and explain their solutions.

Concept Practice Home Activity or Further Classroom Consolidation

Design two right prisms with bases that are polygons. The prisms must have an approximate capacity of 1000 mL.

10.8.1: Designing a Gift Box

Determine the volume of the gift box designed by the students from Trillium School.

Shape of the base of the box:

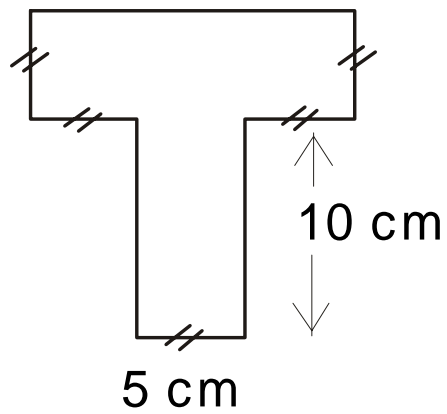

Side view of the box:

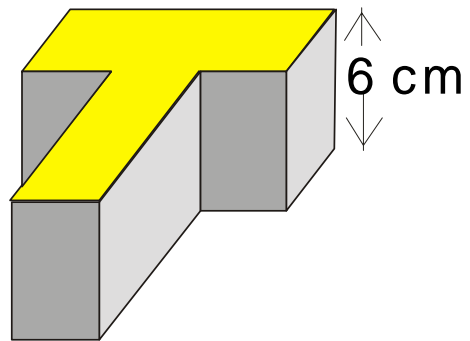

Volume of the box:

Capacity of the box:

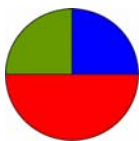
**Math Learning Goals**

- Apply volume and area formulas to explore the relationship between triangular prisms with the same surface area but different volumes.
- Estimate volumes.

Materials

- rectangular tarp or sheet
- connecting cubes
- BLM 10.9.1

Minds On...**Small Groups → Discussion/Presentation**

Students share solutions for homework questions assigned on Day 8 for volume of right prisms with polygon bases. Each small group presents one solution to the whole class.

Whole Class → Investigation

Place a large tarp on the floor/ground. Invite six students to become vertices of a triangular prism tent. Four of the students are to keep their vertices on the ground. They stand on the corners of the tarp. The remaining two students stand on opposite sides of the tarp, equidistant from the ends, to become the fifth and sixth vertices. These two vertices gradually raise the tarp until a tent is formed. Note that the “ground” vertices have to move. Invite two or three other students to be campers.

Students verbalize observations about the tent’s capacity as the tent’s height is increased and decreased. Ask: Does it feel like there is more or less room?

Action!**Pairs → Model Making**

Students simulate the tent experiment using a sheet of paper and connecting cubes. Data may be collected in a two-column chart – height of the tent vs. number of connecting cubes that will fit inside the tent without bulging the sides.

Consolidate Debrief**Think/Pair/Share → Discussion**

In pairs, students respond to the question: Is the following statement sometimes, always, or never true?

Two triangular prisms with the same surface area also have the same volume.

Ask probing questions to ensure that students realize that investigation of this statement differs from the tent investigation since the floor and the triangular sides were ignored in the tent scenario, but cannot be ignored in this question.

Ask students if their conclusion would be the same for closed and open-ended prisms.

Whole Class → Discussion

Discuss how an experiment might be designed to confirm or deny hypotheses about the relationship between surface area and volume.

Home Activity or Further Classroom Consolidation

On worksheet 10.9.1, make two folds using the two solid lines. Form a triangular prism. Imagine that it also has paper on the two triangular ends. Sketch the prism and its net. Take the measurements needed to calculate the surface area (including the two triangular ends) and volume. Label the diagrams with the measurements. Calculate the surface area and volume. Repeat the process for the prism formed using the two broken lines. Make a statement regarding your findings that relates surface area and volume.

Skill Practice

Assessment Opportunities

This activity might be done outside or in a gymnasium. Consider using a rope to hold the peak of the tent in place.

Students might investigate changes when the fold is moved from lengthwise to widthwise.

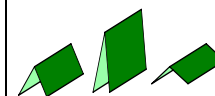

From the model making activity, students should have a sense that the statement is not always true. Since the areas of the triangular ends of the tent prisms were not investigated, encourage students to question the importance of these measurements when considering the statement.

Curriculum Expectations/ Application/Marking Scheme: Assess students’ ability to calculate the area and volume of triangular prisms.

10.9.1: Triangular Prisms



**Math Learning Goals**

- Investigate the relationship between surface area and volume of rectangular prisms.

Materials

- BLM 10.10.1
- interlocking cubes

Assessment Opportunities**Minds On... Whole Class → Discussion**

Use GSP[®]4 file Paper Folding To Investigate Triangular Prisms to check student responses and investigate additional scenarios (Day 9 Home Activity).

[PaperPrism.gsp](#)

Provides a dynamic model of the paper folding activity.

Action! Pairs → Investigation

Pose the question:

If two rectangular prisms have the same volume, do they have the same surface area?

Students might benefit from having interlocking cubes to help them visualize the various shapes and sizes of boxes.

Students investigate, using BLM 10.10.1:

- For prisms with the same volume, is the surface area also the same? (*no*)
- What shape of rectangular prism has the largest surface area for a given volume?

Individual → Written Report

Students individually prepare a written report of their findings.

Communicating/Presentation/Rating Scale: Assess students' ability to communicate in writing and visually their understanding of surface area and volume as a result of their investigation.

Solution

The more elongated the prism, the greater the surface area. The closer the prism becomes to being cube-shaped or spherical, the less surface area it has.

Consolidate Debrief Whole Class → Student Presentations

Students present their findings and apply the mathematics learned in the investigation to answer this question:

Why would a Husky dog curl up in the winter to protect himself from the cold winds when he is sleeping outdoors? (If the dog remains “long and skinny” he has greater surface area exposed to the cold. If he curls up, he has less surface area exposed to the cold, and thus he would lose much less body heat. Although his volume stays the same, his surface area decreases as he becomes more “cube-ish,” or spherical.)

Concept Practice Home Activity or Further Classroom Consolidation

Complete the practice questions.

Provide students with appropriate practice questions.

10.10.1: Wrapping Packages

Three different rectangular prism-shaped boxes each have a volume of 8 cubic units. Does each box require the same amount of paper to wrap? Let's investigate!

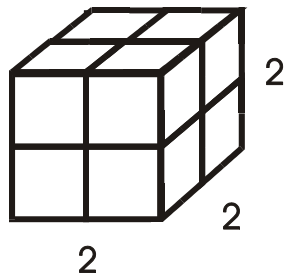

$2 \times 2 \times 2$

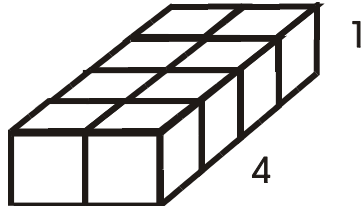

$2 \times 4 \times 1$

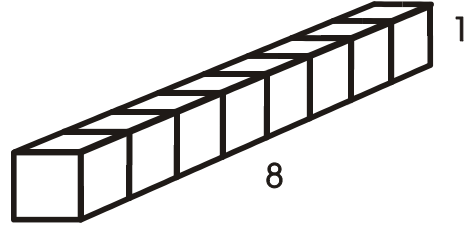

$1 \times 8 \times 1$

- Verify that each rectangular prism illustrated above has a volume of 8 cubic units.
 - Draw the net for each rectangular prism box.
 - Determine the amount of paper required by calculating the surface area. (Ignore the overlapping pieces of paper you would need.)
 - Describe your findings.

- How many different rectangular prism boxes can be designed to have a volume of 24 cubic units?
 - Draw several of the boxes, labelling the dimensions.
 - How much paper is required to wrap each box?
 - Describe your findings.

- Investigate wrapping rectangular prism boxes with a volume of 36 cubic units. Determine the dimensions of the rectangular prism with the greatest surface area.

- Write a report of your findings. Include the following information, justifying your statements.
 - Describe how surface area and volume are related, when the volume remains the same.
 - Describe the shape of a rectangular prism box that uses the most paper for a given volume.
 - Describe the shape of a rectangular prism box that uses the least paper for a given volume.

Paper Folding to Investigate Triangular Prisms (GSP®4 file)

[PaperPrism.gsp](#)

Paper Folding to Investigate Triangular Prisms

If two triangular prisms have the same surface area will they have the same volume?

The dynamic model below shows a piece of paper with two fold lines. If possible, the folded sections are joined so that the paper becomes an open-ended triangular prism.

Change the prism by changing the location of the folds.

Any red point in the dynamic model can be dragged.

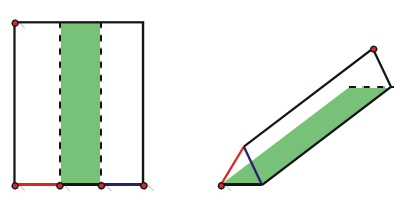

Next Page: Measurements

Paper Triangular Prisms

Fold Paper
Unfold Paper
Show Area of Triangle

Imagine you are looking at the edge of the paper.
 The paper is folded at point D and point E.

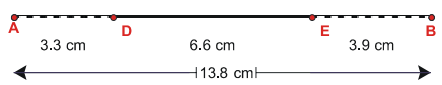

Next Page: Volume

Paper Folding to Investigate Triangular Prisms

1) What paper size are you using?
 2) Where do you want to place your folds?
 3) If two triangular prisms have the same surface area do they have the same volume?

Hide Text

Volume of Prism = 9.8 cm^3
 Surface Area of Prism (without triangles) = 38.6 cm^2
 Surface Area of Prism (with triangles) = 41.3 cm^2

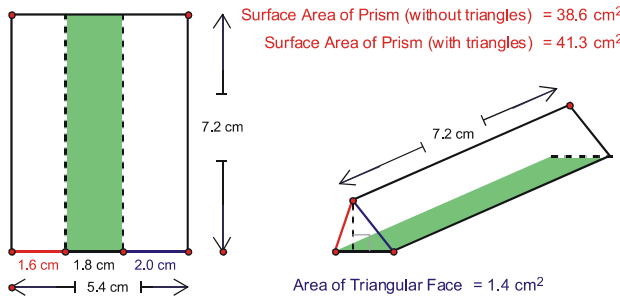

Return to page 1